

WEDGE PRESS 2X2 COMBO

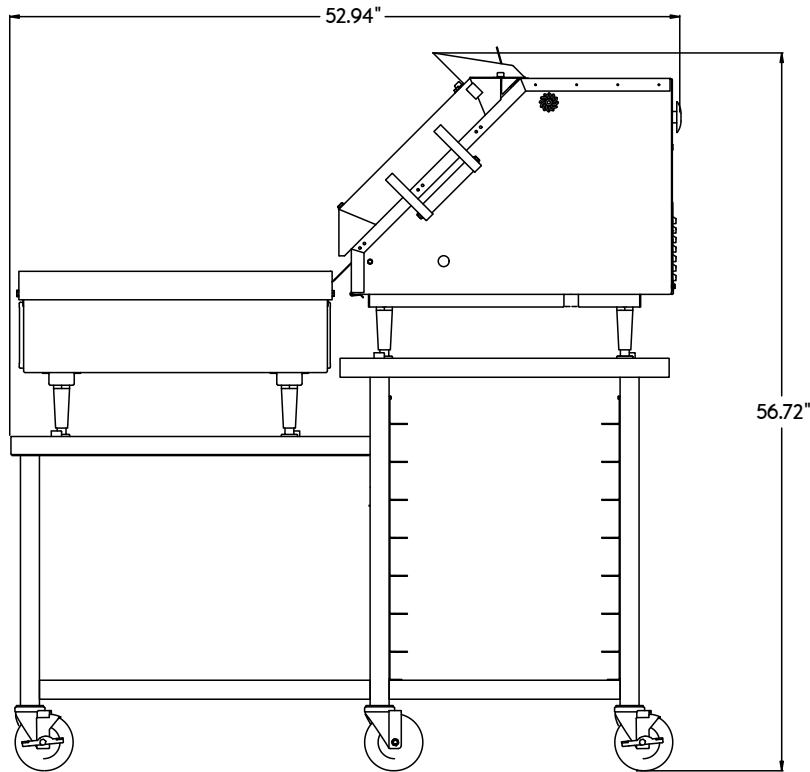



AUTOMATIC FLATBREAD PRESS, GRILL & STAND



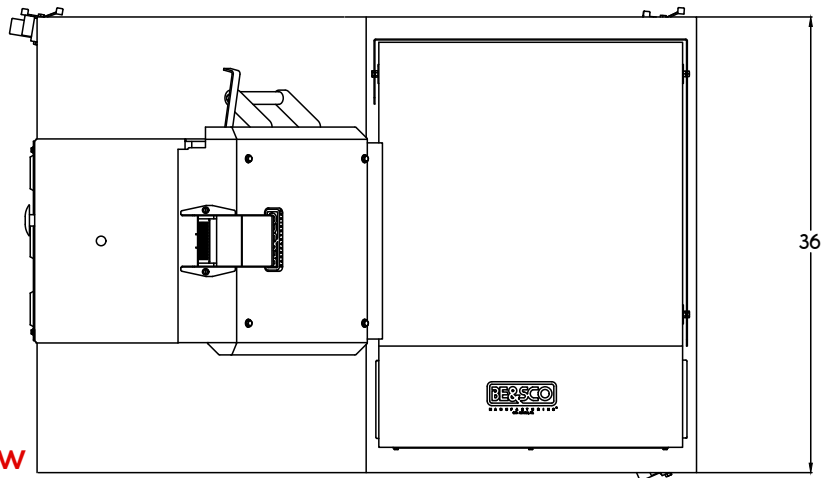

SIDE VIEW

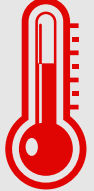

TOP VIEW



- 
 SINGLE PERSON OPERATION
- 
 AUTOMATIC
- 
 TEMPERATURE CONTROLLED PLATES
- 
 AUTO-EJECTED PRODUCT
- 
 DIAMETER FROM 4" TO 12"

DIMENSIONS W/ GRILL	52.94" L X 36" W X 56.72" H	PRESS ELECTRICAL	 PLUG: NEMA 10-50P (250V~)  RECEPTACLE: NEMA 10-50R (250V~)
		GRILL ELECTRICAL	 PLUG: NEMA 10-50P (250V~)  RECEPTACLE: NEMA 10-50R (250V~)



*Certifications Applicable to Press and Grill Only. Certifications Not Applicable to Stands.
 **Production may vary due to the operator experience, diameter and thickness of product.
 BE&SCO EQUIPMENT IS SOLELY INTENDED FOR USE IN A COMMERCIAL FACILITY.



REVISED: 02/25/2021