

# ROTOMAL WEDGE PRESS COMBO

## WEDGE PRESS AND ROTATING TORTILLA GRILL

- The Ultimate in Display Cooking
- Grill Turns While Flour Tortillas cook
- Energy Efficient and Easy to Operate!

SHOWN:  
MODEL 12 PRESS,  
42-14 GRILL,  
29 STAND



## MODEL 42-14 SPEC

120 Volts  
5 Amps  
Cycles/Phase: 60HZ/Single  
D 66 cm x 36 cm x 44 cm  
W 37.75" x H 40.50"  
W 96 cm x H 103 cm  
Weight: 300lbs. / 137 kg.  
Natural Gas 29,600 BTU/HR

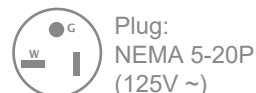

Plug:  
NEMA 5-20P  
(125V ~)



Receptacle:  
NEMA 5-20R  
(125V ~)

## MODEL 12 SPEC

220/240 Volts  
23.4 Amps / 5.6KW  
Cycles/Phase: 60HZ/Single  
D 66 cm x 46 cm x 66 cm  
L 26" x W 18" x H 26"  
Weight: 200lbs. / 91 kg.

Tortilla Production:  
Up to 780 to 900 per hour

Tortilla Diameter:  
4" / 10cm to 12" / 30.5cm

\*Tortilla production may vary due to operator experience, diameter and thickness of tortillas.



Plug:  
NEMA 10-50P  
(250V ~)



Receptacle:  
NEMA 10-50R  
(250V ~)

\*BE&SCO equipment is solely intended for use in a commercial facility.



200 Lombrano St · San Antonio, TX 78207 USA  
Office: (210) 734-5124 · Fax: (210) 737-3925  
Toll Free: 1-800-683-0928  
Email: sales@bescomfg.com · Website: www.bescomfg.com  
Visit our website to view video www.bescomfg.com



Certifications Applicable to Press and Grill Only  
\*Certifications Not Applicable to Stands

Revised: 03/04/2020

# Rotomal Grill & Wedge Press Combo

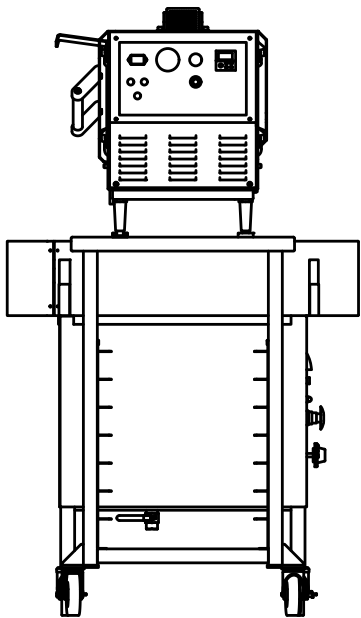
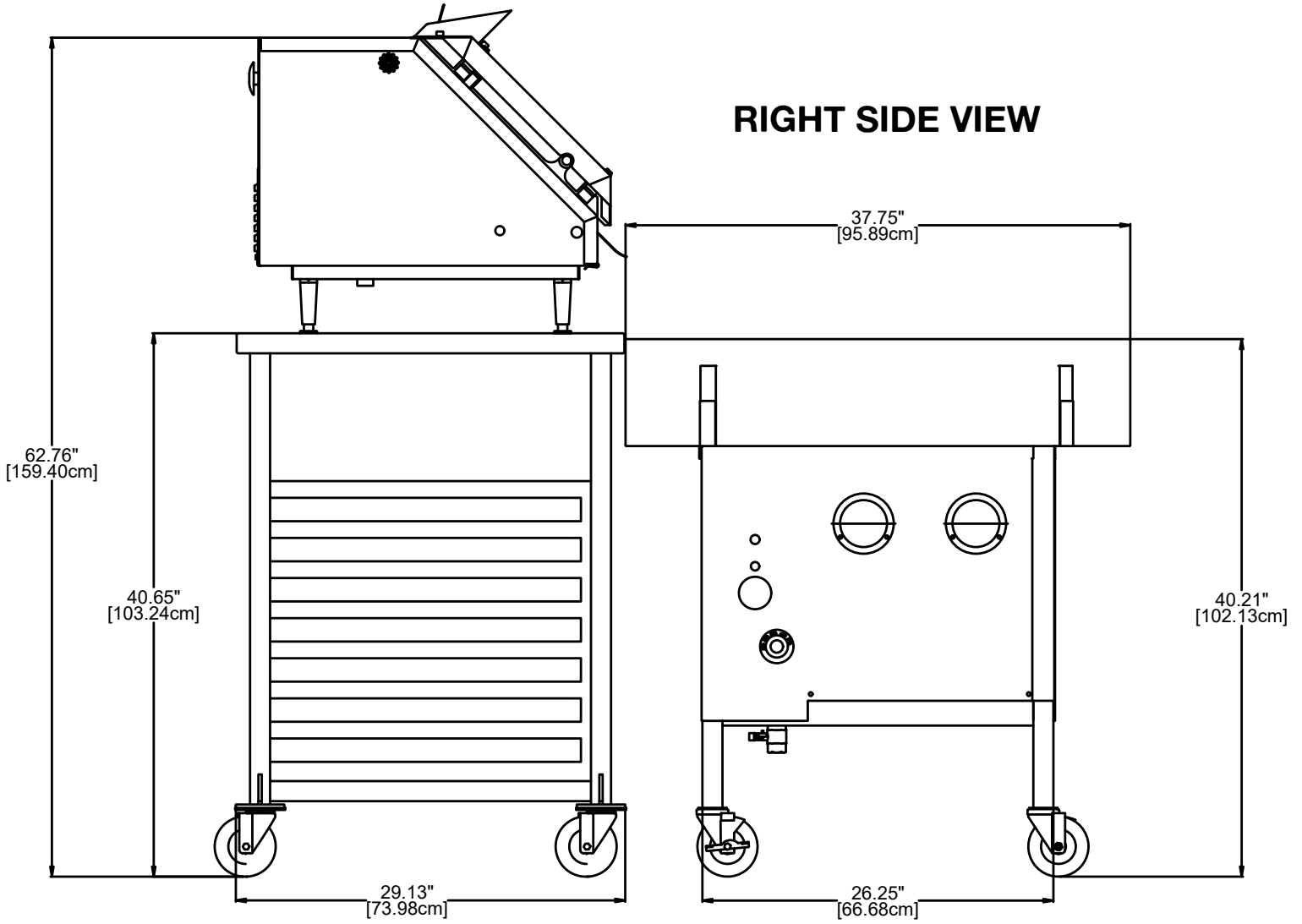

**BACK**

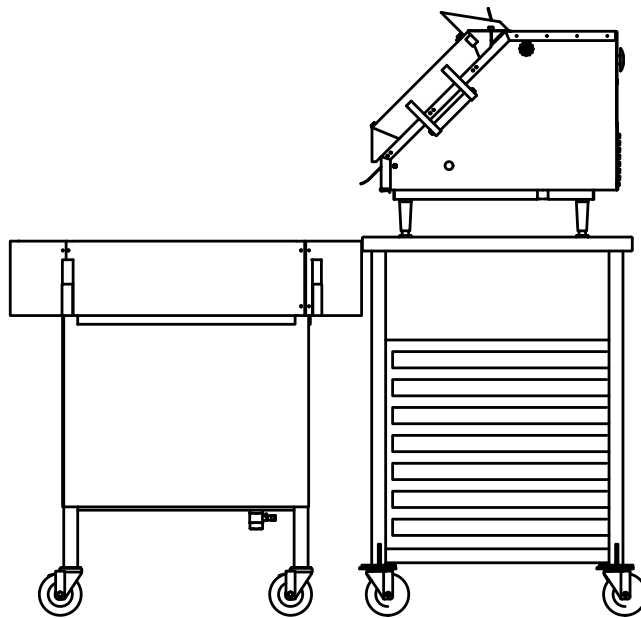

**LEFT SIDE VIEW**

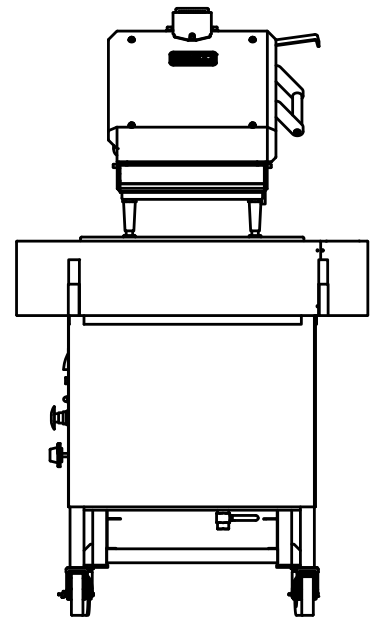

**FRONT**