

12-18 WEDGE PRESS ROTOMAL COMBO

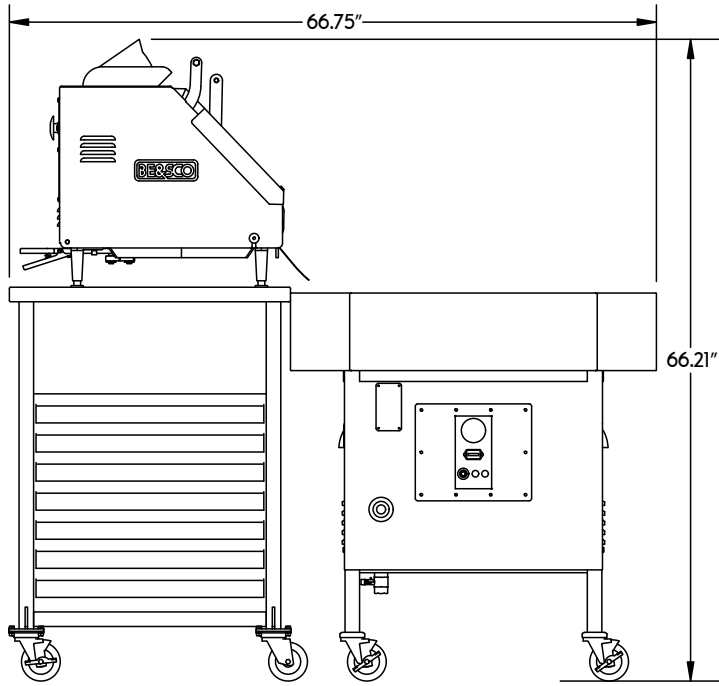



AUTOMATIC FLATBREAD PRESS, GRILL & STAND

SIDE VIEW

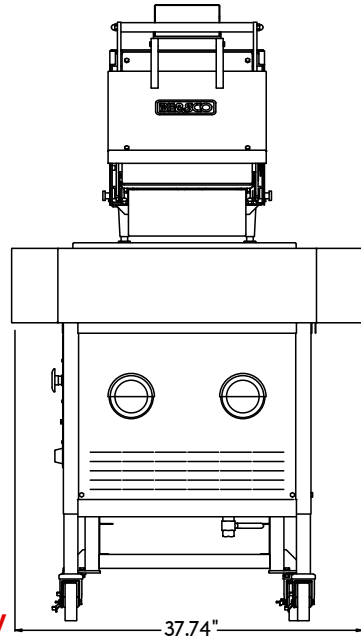

FRONT VIEW

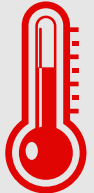

- 
SINGLE PERSON OPERATION
- 
AUTOMATIC
- 
TEMPERATURE CONTROLLED PLATES
- 
AUTO-EJECTED PRODUCT
- 
DIAMETER FROM 4" TO 13"

DIMENSIONS W/ GRILL	66.75" L X 37.74" W X 66.21" H	PRESS ELECTRICAL	 PLUG: NEMA 10-50P (250V~)	 RECEPTACLE: NEMA 10-50R (250V~)
		GRILL ELECTRICAL	 PLUG: NEMA 6-20P (250V~)	 RECEPTACLE: NEMA 6-20R (250V~)



*CE Certification Applicable to Press Only. ETL and NSF Certifications Applicable to Press and Grill Only. Certifications Not Applicable to Stand.

**Production may vary due to the operator experience, diameter and thickness of product.

BE&SCO EQUIPMENT IS SOLELY INTENDED FOR USE IN A COMMERCIAL FACILITY.



REVISED: 02/04/2022