

MINI WEDGE ROTOMAL COMBO

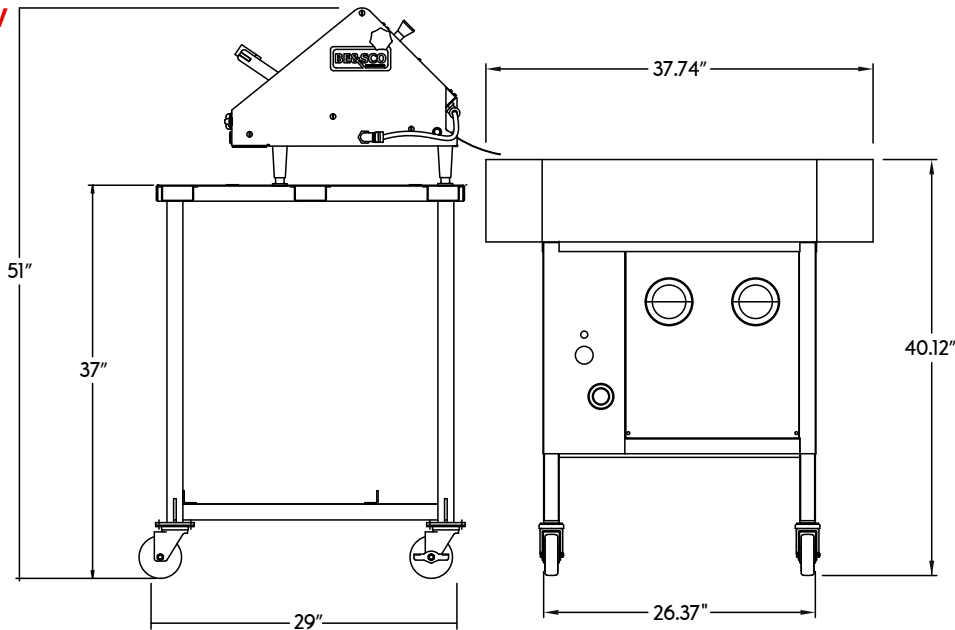



MANUAL FLATBREAD PRESS, GRILL & STAND



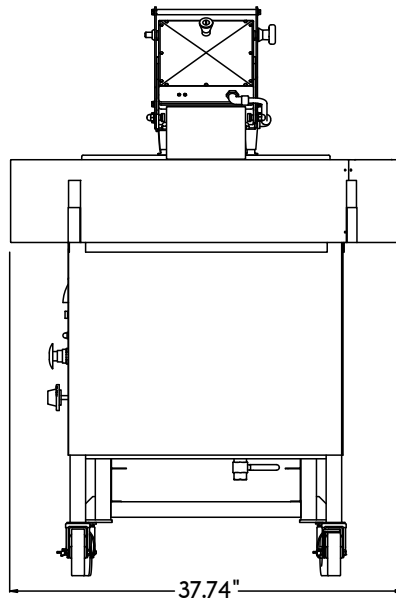

SIDE VIEW



FRONT VIEW



- 
SINGLE PERSON OPERATION
- 
MANUAL
- 
TEMPERATURE CONTROLLED PLATES
- 
AUTO-EJECTED PRODUCT
- 
DIAMETER FROM 4" TO 7"

DIMENSIONS W/ GRILL	66.74" L X 37.74" W X 51" H	PRESS ELECTRICAL	 PLUG: NEMA 5-20P (125V~)	 RECEPTACLE: NEMA 5-20R (125V~)
		GRILL ELECTRICAL	 PLUG: NEMA 5-20P (125V~)	 RECEPTACLE: NEMA 5-20R (125V~)



*CE Certification Applicable to Press Only. ETL and NSF Certifications Applicable to Press and Grill Only. Certifications Not Applicable to Stand.

**Production may vary due to the operator experience, diameter and thickness of product.

BESCO EQUIPMENT IS SOLELY INTENDED FOR USE IN A COMMERCIAL FACILITY.



REVISED: 03/05/2021